

Steeple #SB-28

figure - 1

DESIGN PARAMETERS
 The unit described in these drawings is engineered to adequately support the loads created by a wind velocity of 120 MPH at a height of 50 feet above ground using ACSCE 7-95 exposure category "C". An additional 2 feet in height was added to the base during these calculations to account for variations in roof pitch, etc.

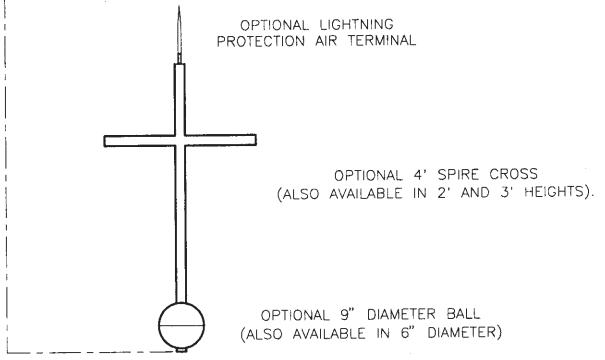
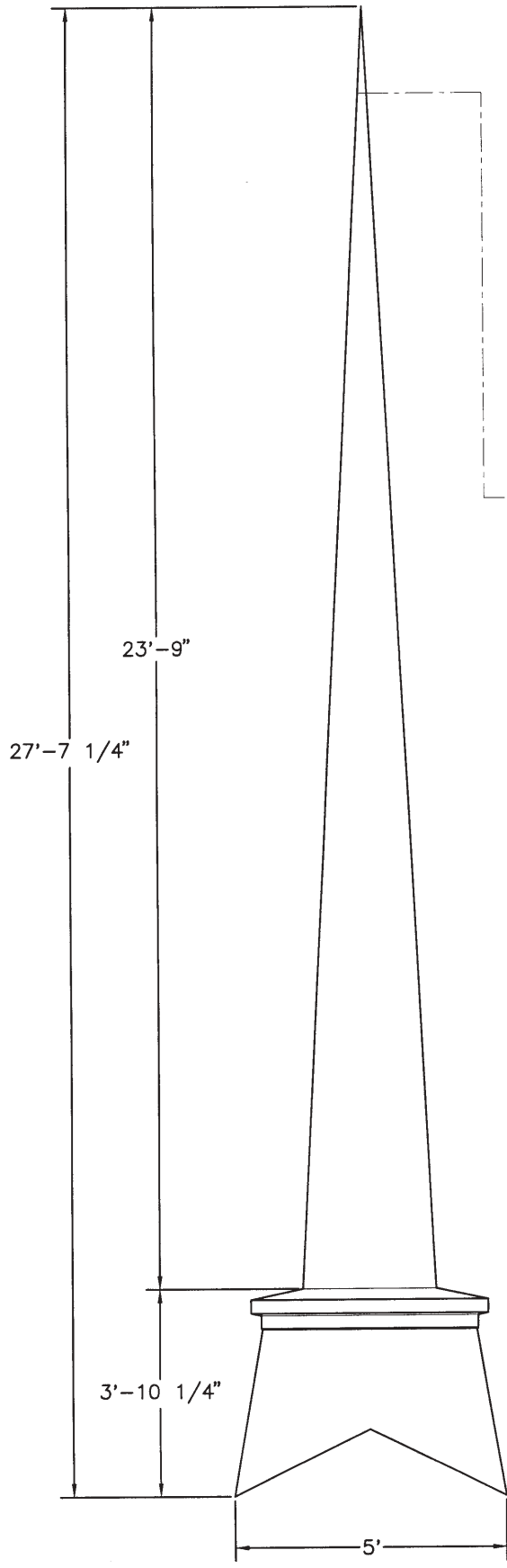

ALL UNITS WERE ENGINEERED WITH A 4' CROSS AND 9" Ø BALL INSTALLED PER FIBERGLASS SPECIALTIES, INC. STANDARD MOUNTING PROCEDURES.

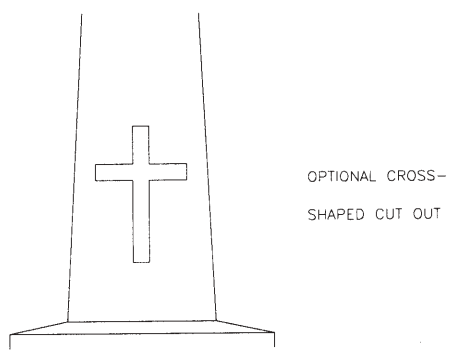

12
 VERIFY ROOF PITCH

Dimensions and details are subject to change without notice. All cupola and steeple units are fabricated using minimal standing seams unless otherwise noted. All cupola and steeple units are designed to be erected on a completed roofing system and are not guaranteed to be leak proof.

Steeple #SB-28

figure - 2

DESIGN PARAMETERS
 The unit described in these drawings is engineered to adequately support the loads created by a wind velocity of 120 MPH at a height of 50 feet above ground using ACSCE 7-95 exposure category "C". An additional 2 feet in height was added to the base during these calculations to account for variations in roof pitch, etc.

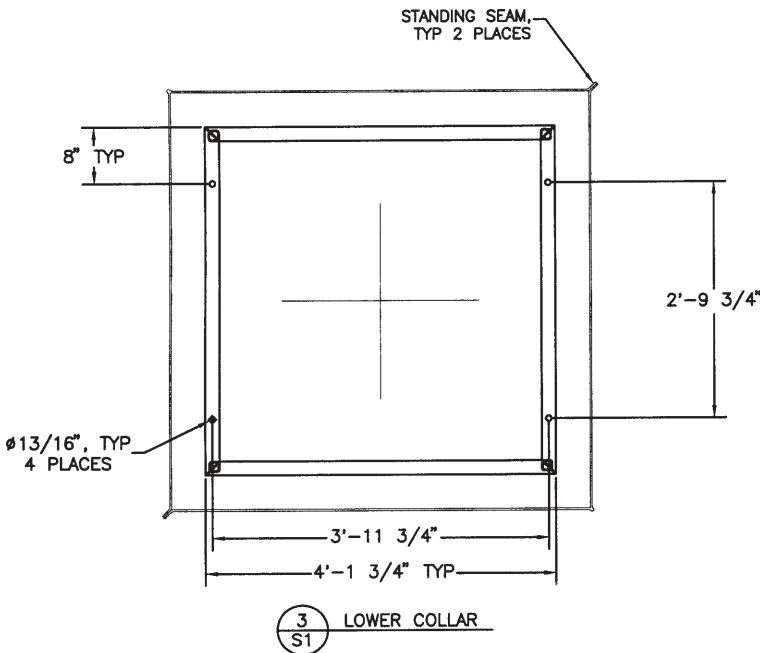

NOTE: ABOVE DIMENSIONS WILL APPLY TO FLAT BASE AND ALL ROOF PITCHES UP TO AND INCLUDING 9/12. DIMENSIONS FOR STEEPER PITCHES AVAILABLE UPON REQUEST.

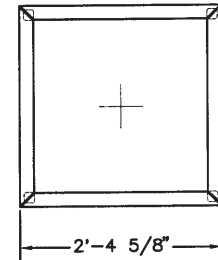

4 UPPER COLLAR

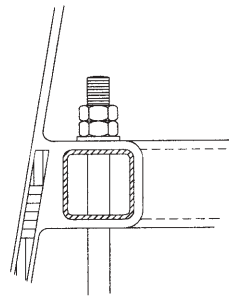

2 ANCHOR DETAIL

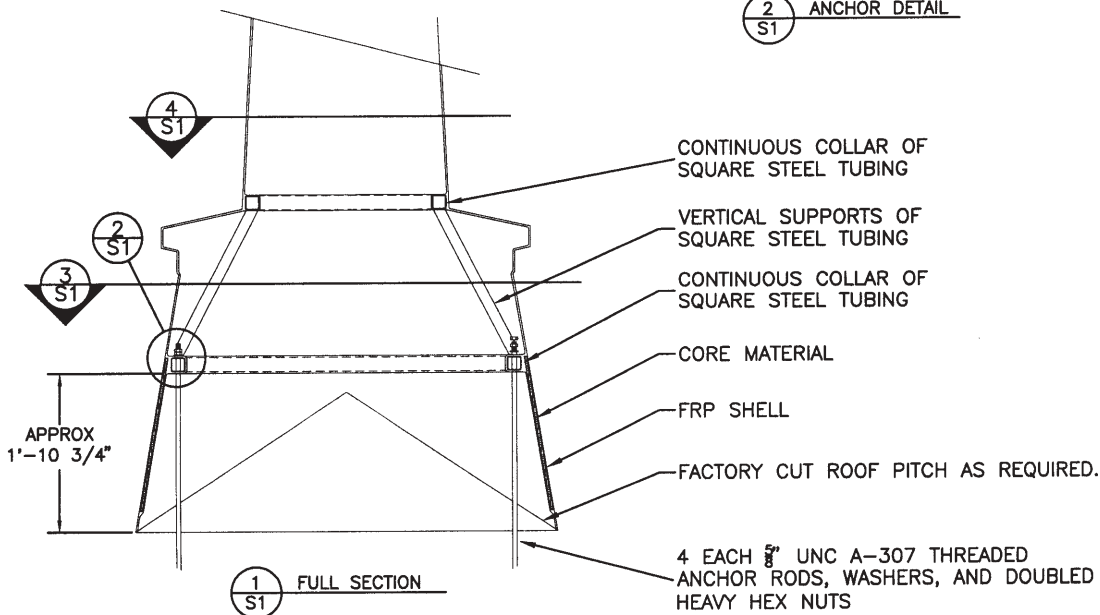

Dimensions and details are subject to change without notice. All cupola and steeple units are fabricated using minimal standing seams unless otherwise noted. All cupola and steeple units are designed to be erected on a completed roofing system and are not guaranteed to be leak proof.