

Steeple #22

figure - 1

DESIGN PARAMETERS

The unit described in these drawings is engineered to adequately support the loads created by a wind velocity of 120 MPH at a height of 50 feet above ground using ACSCE 7-95 exposure category "C". An additional 2 feet in height was added to the base during these calculations to account for variations in roof pitch, etc.

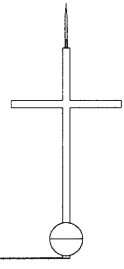
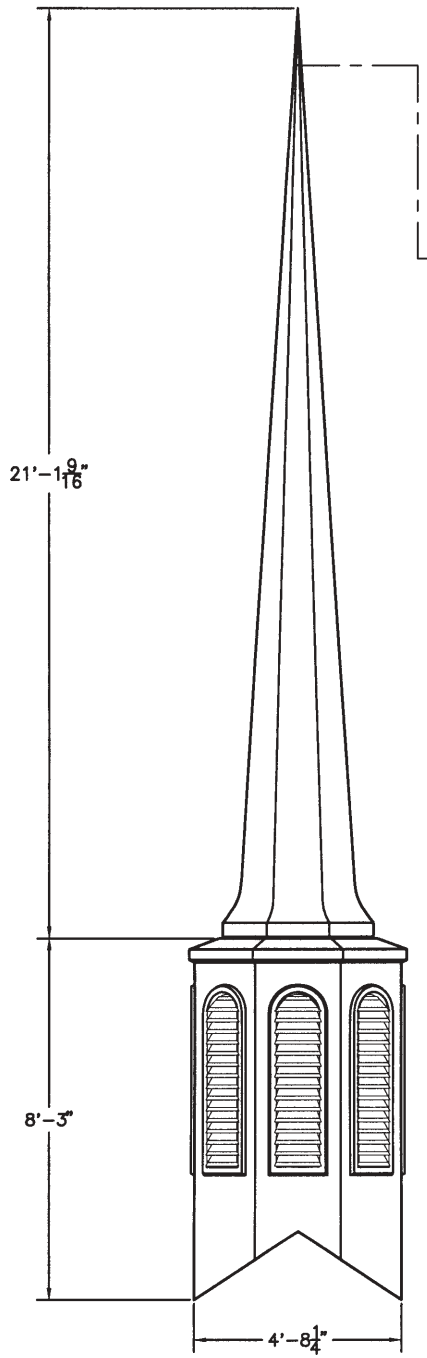

OPTIONAL LIGHTNING PROTECTION AIR TERMINAL

OPTIONAL 4' SPIRE CROSS
(ALSO AVAILABLE IN 2' AND 3' HEIGHTS).

OPTIONAL 9" DIAMETER BALL
(ALSO AVAILABLE IN 6" DIAMETER)

ALL UNITS WERE ENGINEERED WITH A 4' CROSS AND 9"Ø BALL INSTALLED PER FIBERGLASS SPECIALTIES, INC. STANDARD MOUNTING PROCEDURES.

SPIRE UNIT #619

BASE CUPOLA UNIT #601 WITH VENTED LOUVERS
(ALSO AVAILABLE WITH FALSE LOUVERS OR KRINKLGLAS® WINDOWS)

1 ELEVATION
E1

Dimensions and details are subject to change without notice. All cupola and steeple units are fabricated using minimal standing seams unless otherwise noted. All cupola and steeple units are designed to be erected on a completed roofing system and are not guaranteed to be leak proof.

Steeple #22

figure - 2

DESIGN PARAMETERS

The unit described in these drawings is engineered to adequately support the loads created by a wind velocity of 120 MPH at a height of 50 feet above ground using ACSCE 7-95 exposure category "C". An additional 2 feet in height was added to the base during these calculations to account for variations in roof pitch, etc.

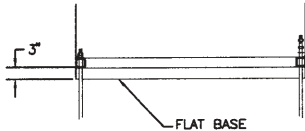
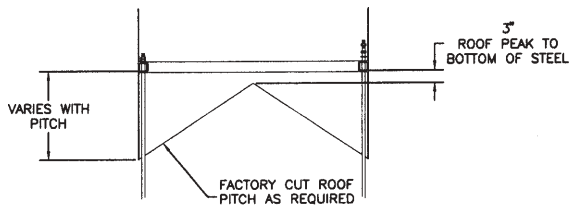

(4) BASE DETAILS
S1

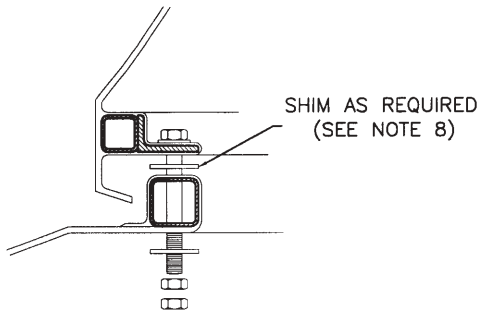

(2) BOLTING DETAIL
S1

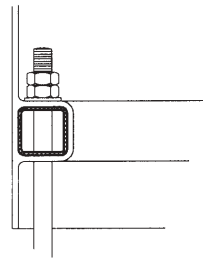

(3) ANCHOR DETAIL
S1

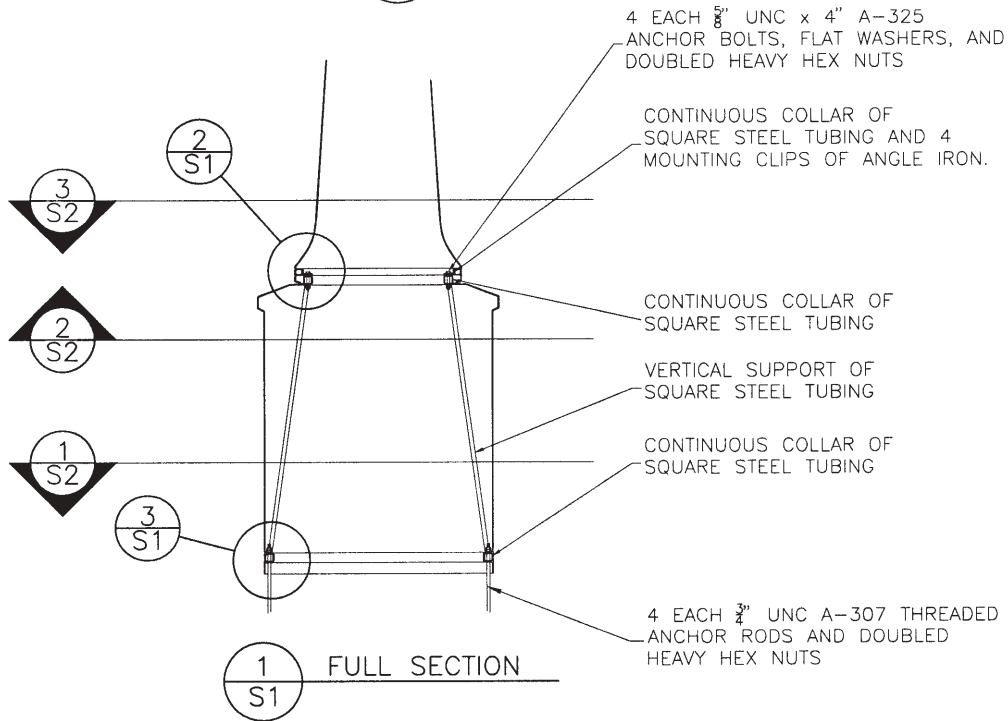

(1) FULL SECTION
S1

Steeple #22

figure - 3

DESIGN PARAMETERS

The unit described in these drawings is engineered to adequately support the loads created by a wind velocity of 120 MPH at a height of 50 feet above ground using ACSCE 7-95 exposure category "C". An additional 2 feet in height was added to the base during these calculations to account for variations in roof pitch, etc.

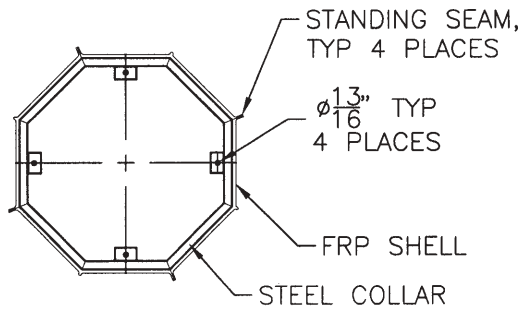

3
S2
BASE OF SP-619
PLAN VIEW

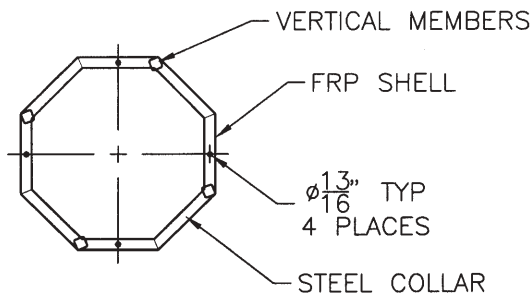

2
S2
TOP OF CU-601
REFLECTED VIEW

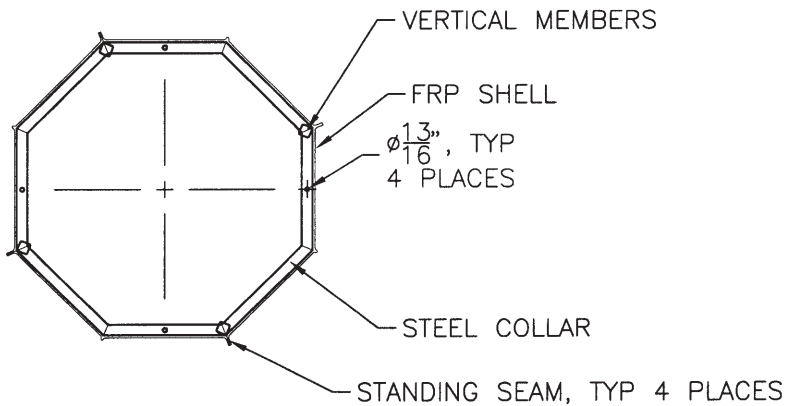

1
S2
BASE OF CU-601
PLAN VIEW