

Steeple #24 B

figure - 1

DESIGN PARAMETERS
 The unit described in these drawings is engineered to adequately support the loads created by a wind velocity of 120 MPH at a height of 50 feet above ground using ACSCE 7-95 exposure category "C". An additional 2 feet in height was added to the base during these calculations to account for variations in roof pitch, etc.

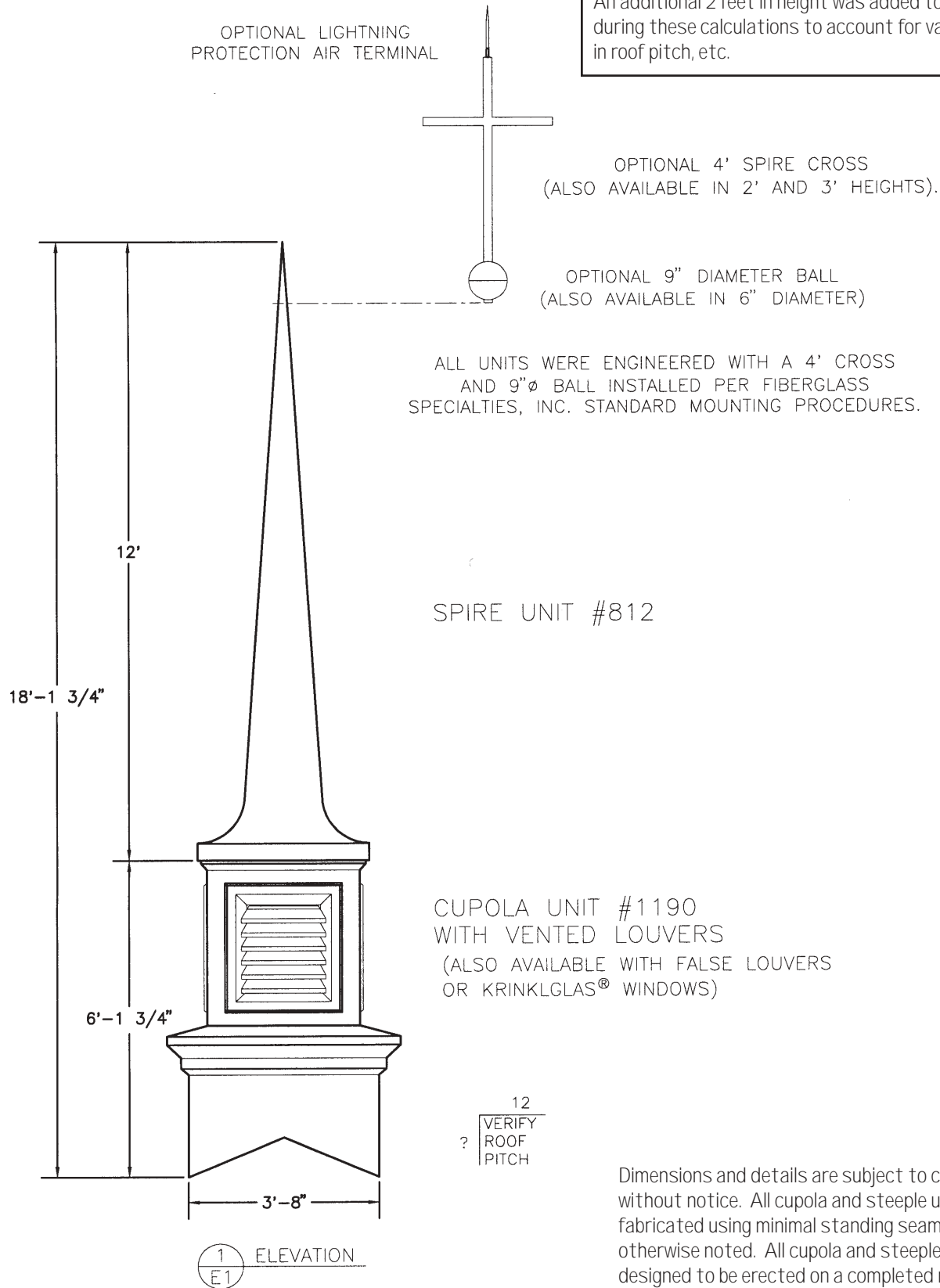

Dimensions and details are subject to change without notice. All cupola and steeple units are fabricated using minimal standing seams unless otherwise noted. All cupola and steeple units are designed to be erected on a completed roofing system and are not guaranteed to be leak proof.

Steeple #24 B

figure - 2

DESIGN PARAMETERS
 The unit described in these drawings is engineered to adequately support the loads created by a wind velocity of 120 MPH at a height of 50 feet above ground using ACSCE 7-95 exposure category "C". An additional 2 feet in height was added to the base during these calculations to account for variations in roof pitch, etc.

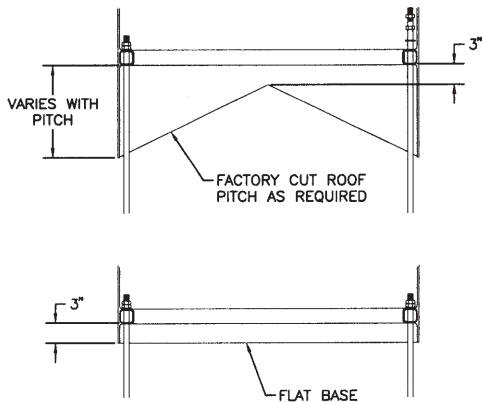

5 BASE DETAILS

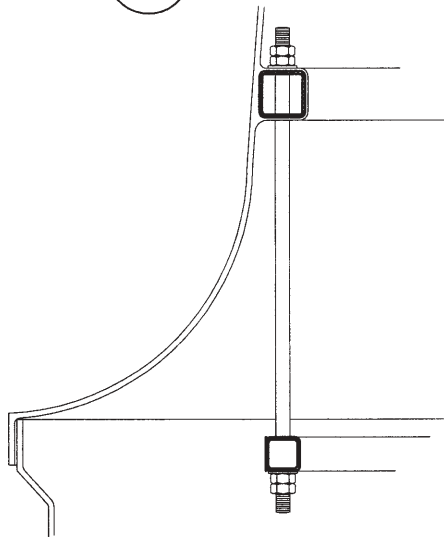

3 ANCHOR DETAIL

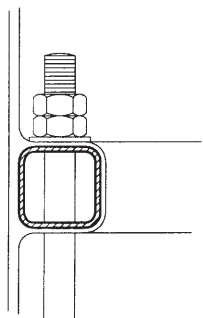

2 ANCHOR DETAIL

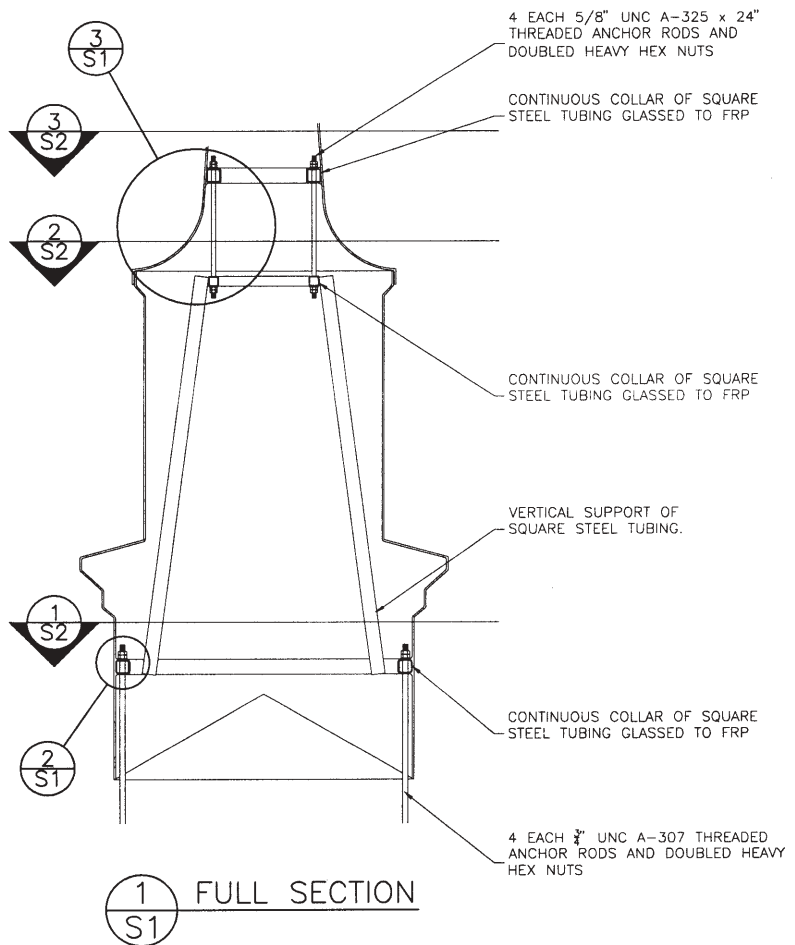

1 FULL SECTION

Steeple #24 B

figure - 3

DESIGN PARAMETERS

The unit described in these drawings is engineered to adequately support the loads created by a wind velocity of 120 MPH at a height of 50 feet above ground using ACSCE 7-95 exposure category "C". An additional 2 feet in height was added to the base during these calculations to account for variations in roof pitch, etc.

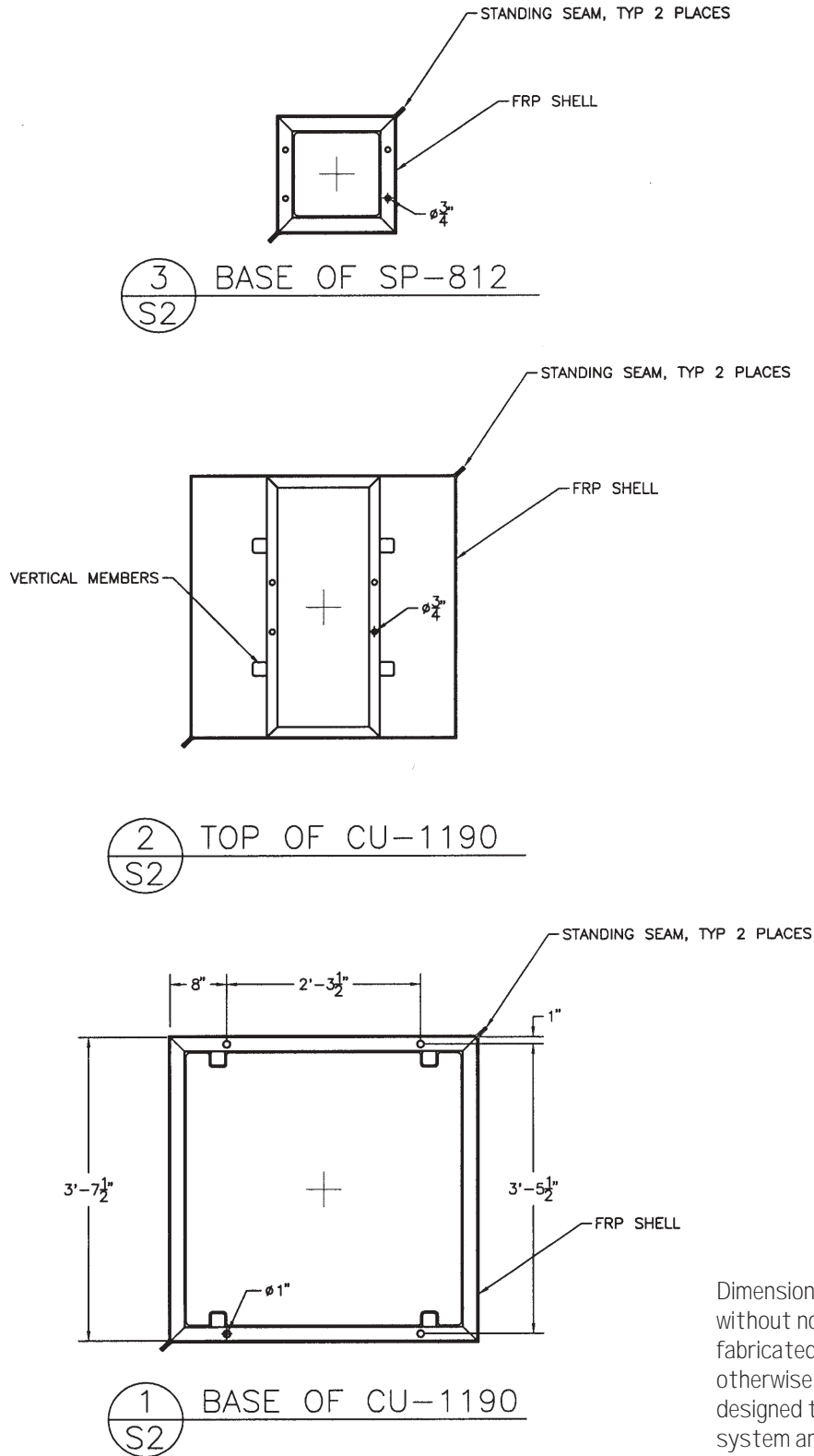

Dimensions and details are subject to change without notice. All cupola and steeple units are fabricated using minimal standing seams unless otherwise noted. All cupola and steeple units are designed to be erected on a completed roofing system and are not guaranteed to be leak proof.